



## *Transmission & Conversion*

- Workpackage activities and first findings -

EWEC 2008 Session BW2 "UpWind"

Tuesday 1st April 2008 11:00 - 12:30

Jan Hemmelmann, GE Global Research



SIXTH FRAMEWORK PROGRAMME

EWEC 2008 Session BW2 "UpWind" – Transmission & Conversion



# Outline

## ✧ Mechanical Transmission

- Comparison of turbine measurements with simulation

## ✧ Generators

- Comparison of different generator configurations
- Electromagnetic optimization
- Optimization of the mechanical structure

## ✧ Power Electronics

- Converter topologies



# Global modeling approach for evaluation of “dynamic wind turbine power train loads”

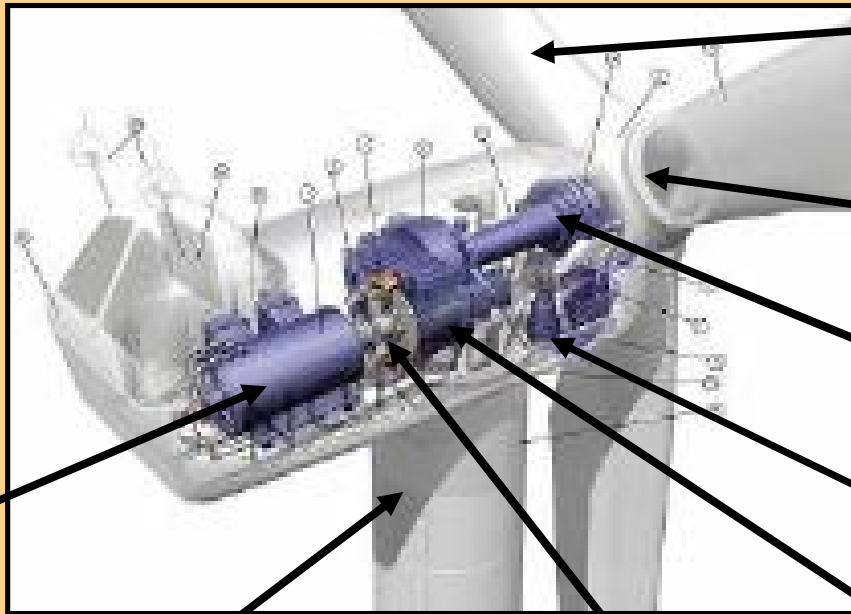

## Rotor blades & aero-elasticity:

Blades: Beam Elements or Super-Elements & strong aerodynamic coupling using BEM-Theory.

## Pitch & control:

Pitch drives: MBS-modelling  
Pitch angle: external controller DLL's

## Rotor shaft & main bearings:

Shaft: beam elements  
Bearings: specific MBS-approach

## Bedplate-main frame:

Super-elements, beams etc..

## Tower:

beam elements & aerodynamic interaction (tower shadow)

## Generator & control:

rotor & stator: beam model  
generator torque: external controller DLL

## Disk brake, Slip clutch:

MBS approach:

## Gearbox:

Bearings: non-linear  
Gears: flexible non-linear  
Shafts: beams  
Housing: super-element  
Planet carrier: super-element



# Sensors locations: measurement, simulation

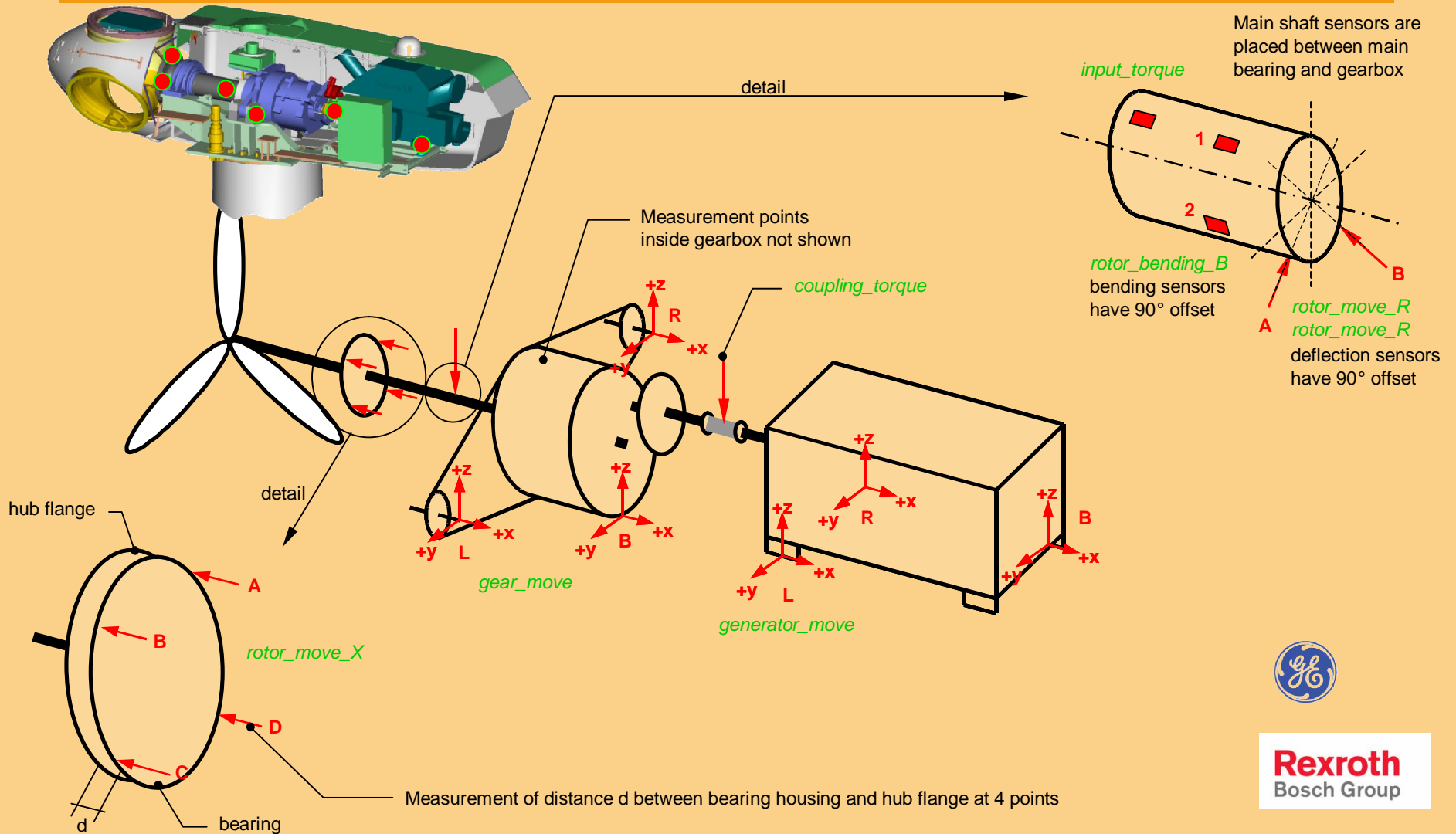

# Sensors locations within gearbox

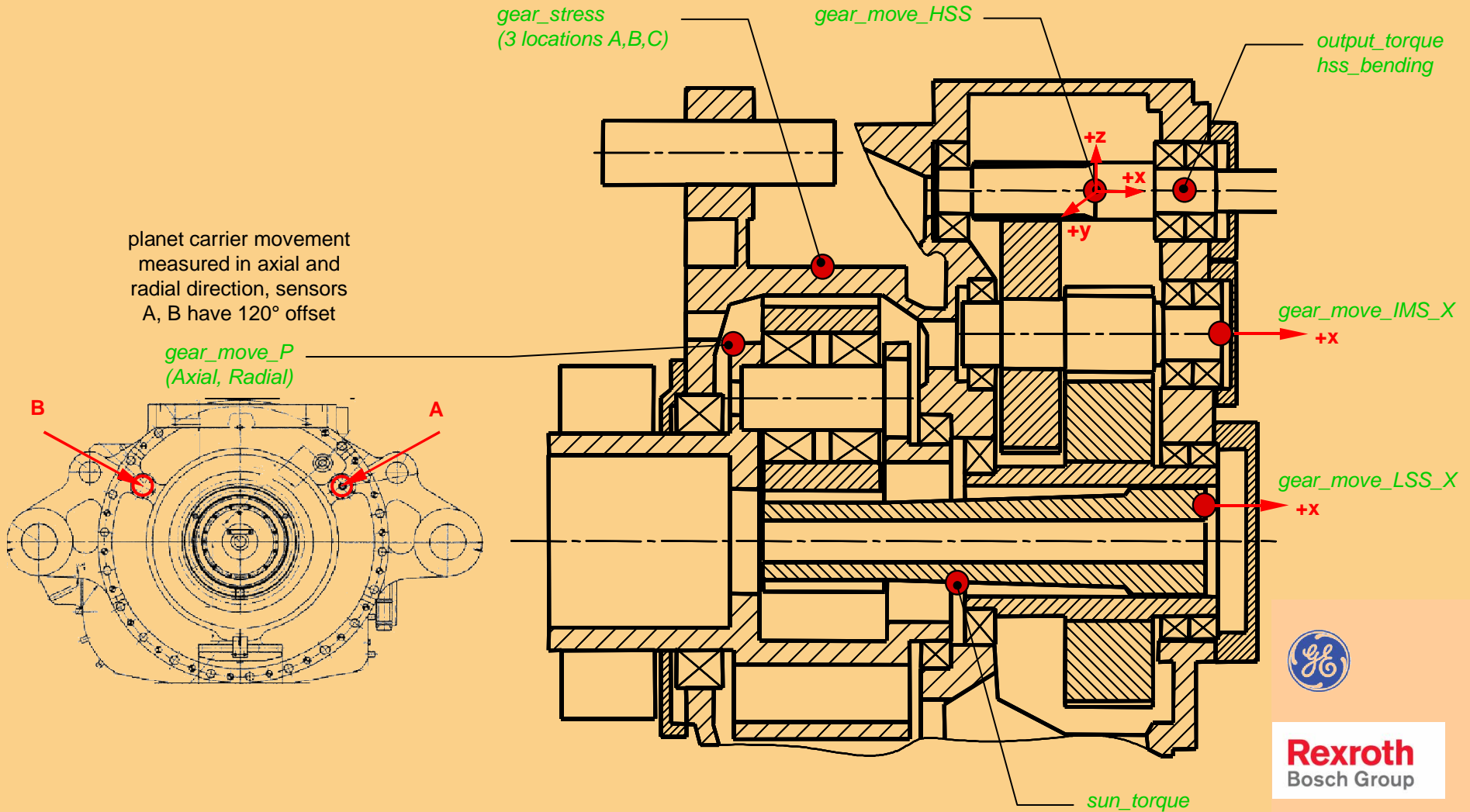

SIXTH FRAMEWORK PROGRAMME

EWEC 2008 Session BW2 "UpWind" – Transmission & Conversion



# Some interesting findings in measurements

E-Stop Event

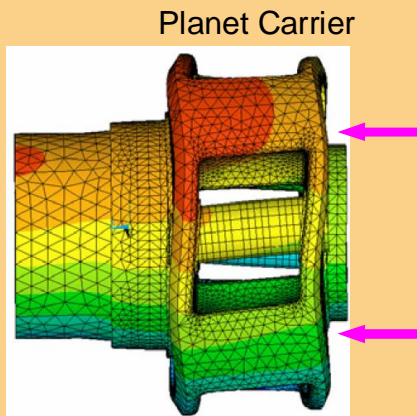

Planet Carrier

sensor positions 120°

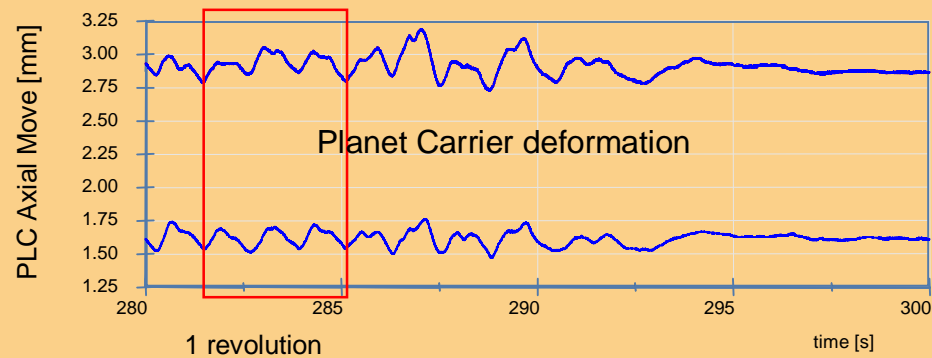
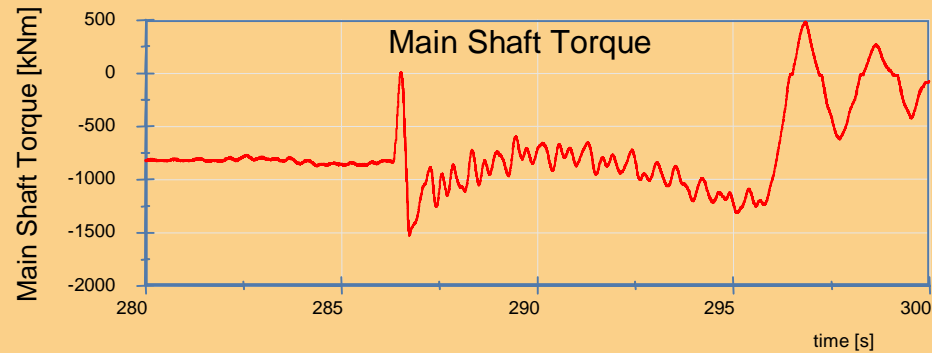

**Rexroth**  
Bosch Group



SIXTH FRAMEWORK PROGRAMME

EWEC 2008 Session BW2 "UpWind" – Transmission & Conversion

UpWind

# Rotor torque, blade pitch, power, speed

Estop ( $V_{avg} = 7.0$  m/s)

Comparison of experimental data with simulation

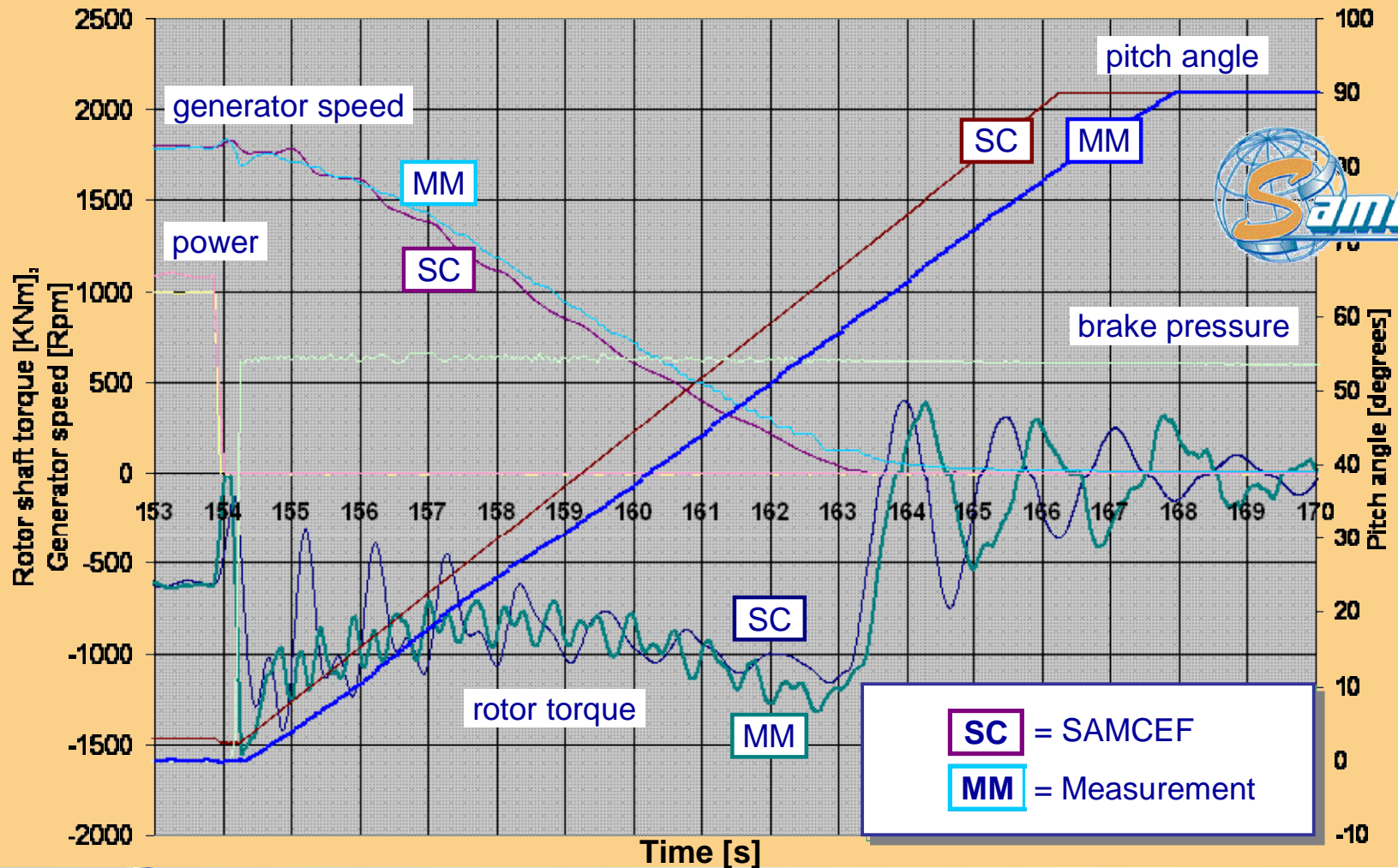

SIXTH FRAMEWORK PROGRAMME

EWEC 2008 Session BW2 "UpWind" – Transmission & Conversion



# Torque arm displacement - longitudinal

Estop (V\_avg = 7.0 m/s)

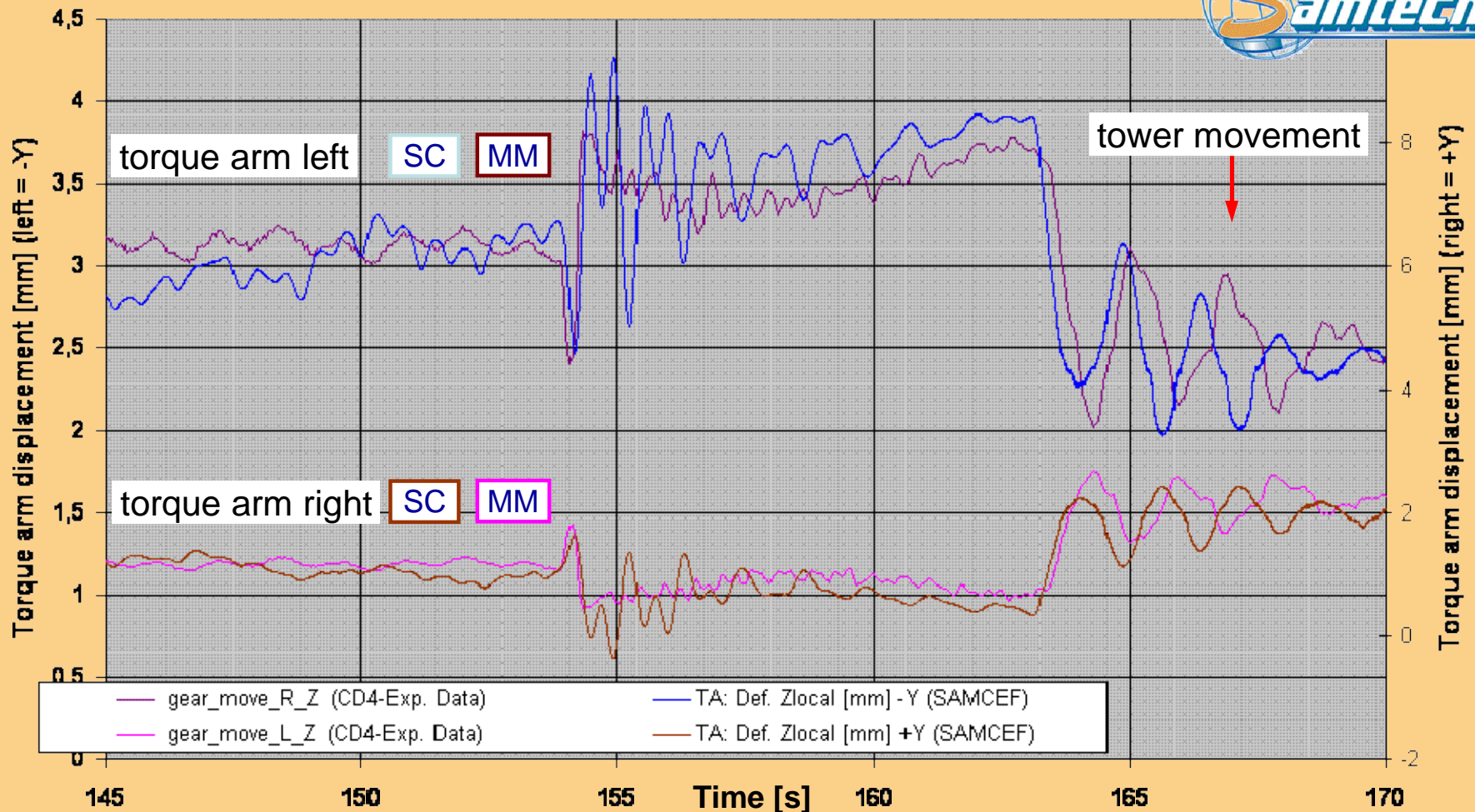

SIXTH FRAMEWORK PROGRAMME

EWEC 2008 Session BW2 "UpWind" - Transmission & Conversion



# Low speed shaft displacement - axial

Estop (V\_avg = 7.0 m/s)

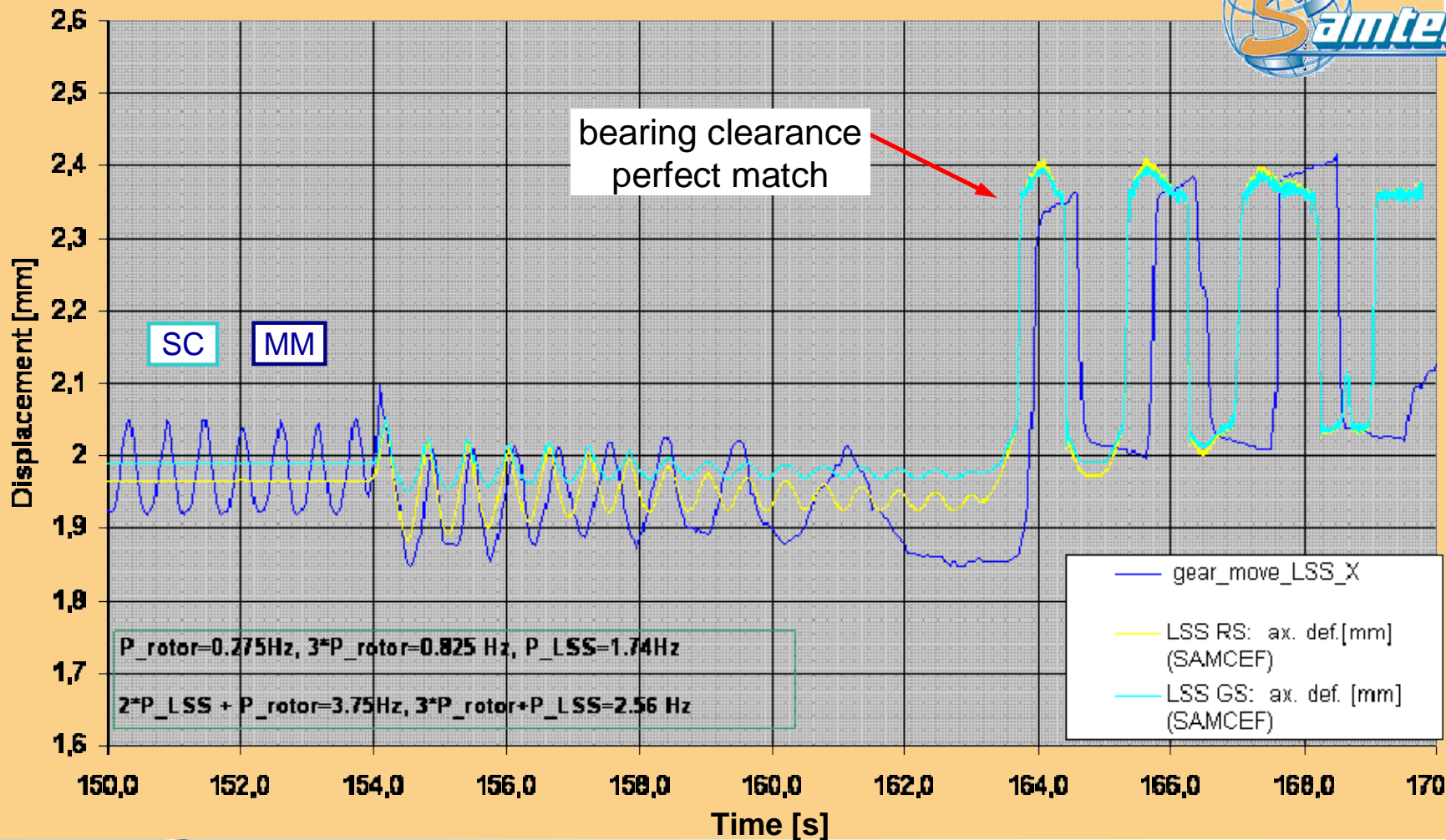

SIXTH FRAMEWORK PROGRAMME

EWEC 2008 Session BW2 "UpWind" – Transmission & Conversion



# High speed shaft displacement - axial

Estop ( $V_{avg} = 7.0$  m/s)

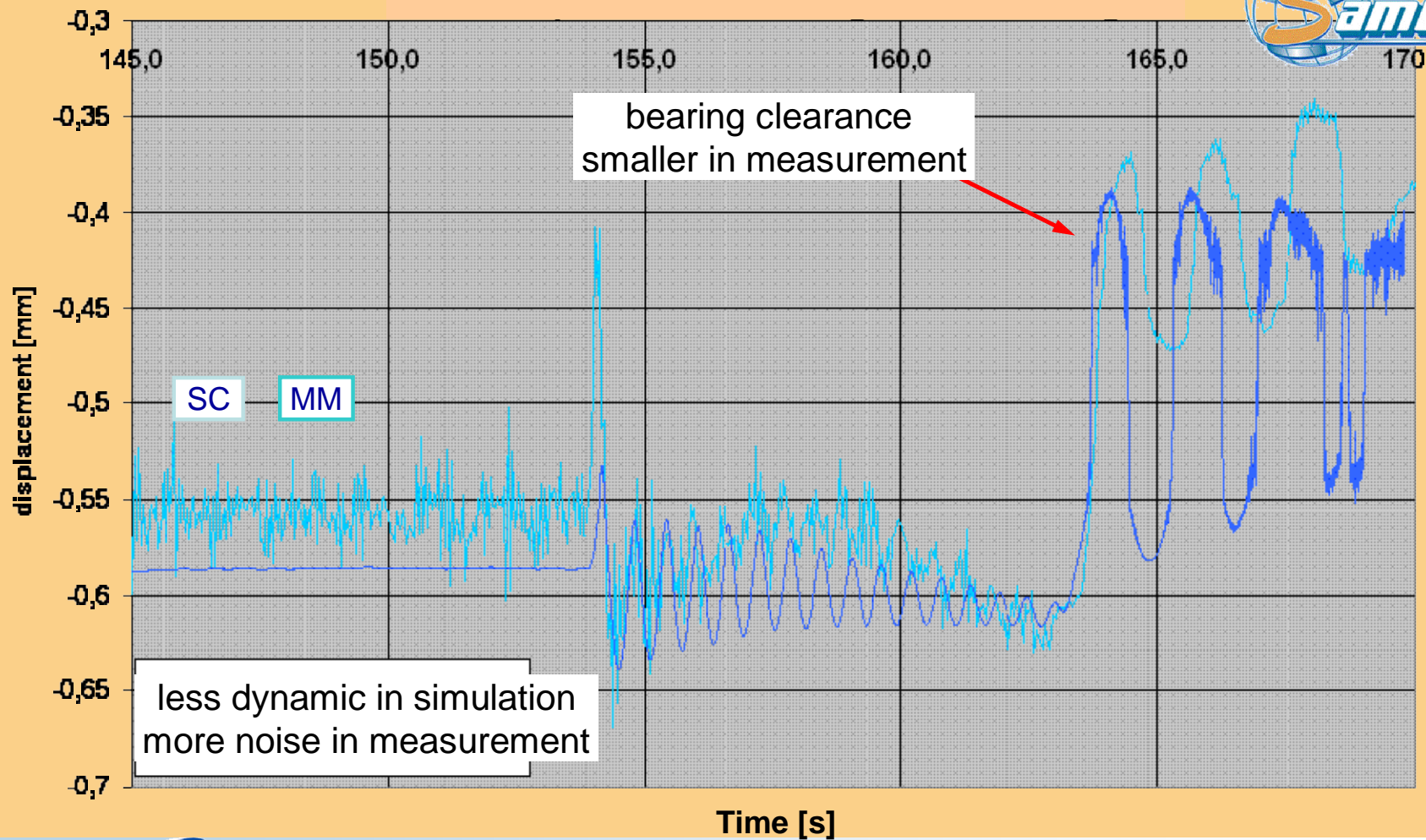

SIXTH FRAMEWORK PROGRAMME

EWEC 2008 Session BW2 "UpWind" - Transmission & Conversion



# Modeling of defects

Two types of defects are introduced as parameters in the S4WT model:

1) Pitch error of 1 blade:  $0.1^\circ$ :  
=> excitation of frequency  $P_{\text{rotor}}$

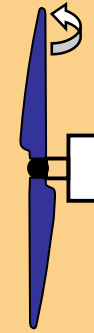

2) Misalignment of rotor shaft and planet carrier:  
=> excitation of frequency  $P_{\text{rotor}}$

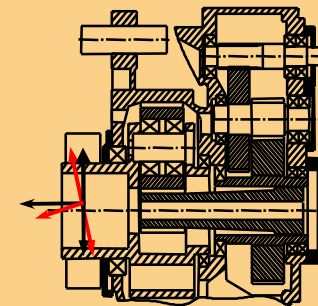

SIXTH FRAMEWORK PROGRAMME

EWEC 2008 Session BW2 "UpWind" – Transmission & Conversion

UpWind 

# Pitch error & misalignment of main shaft

- § Torque arm displacements show
- $3P_{\text{rotor}}$  : tower shadow
  - $1P_{\text{rotor}}$  : pitch error

1  $P_{\text{rotor}}$  = 0.275Hz  
 3  $P_{\text{rotor}}$  = 0.825 Hz

Gearbox movement at torque arm bushings (longitudinal – wind direction)

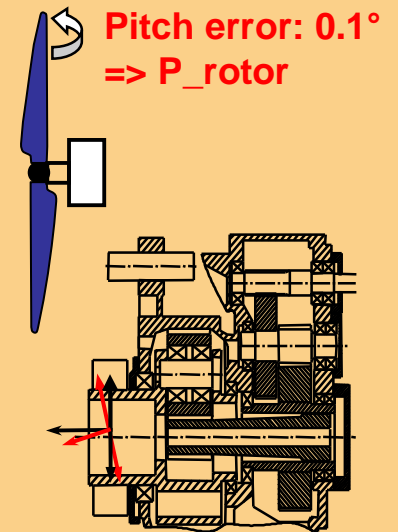
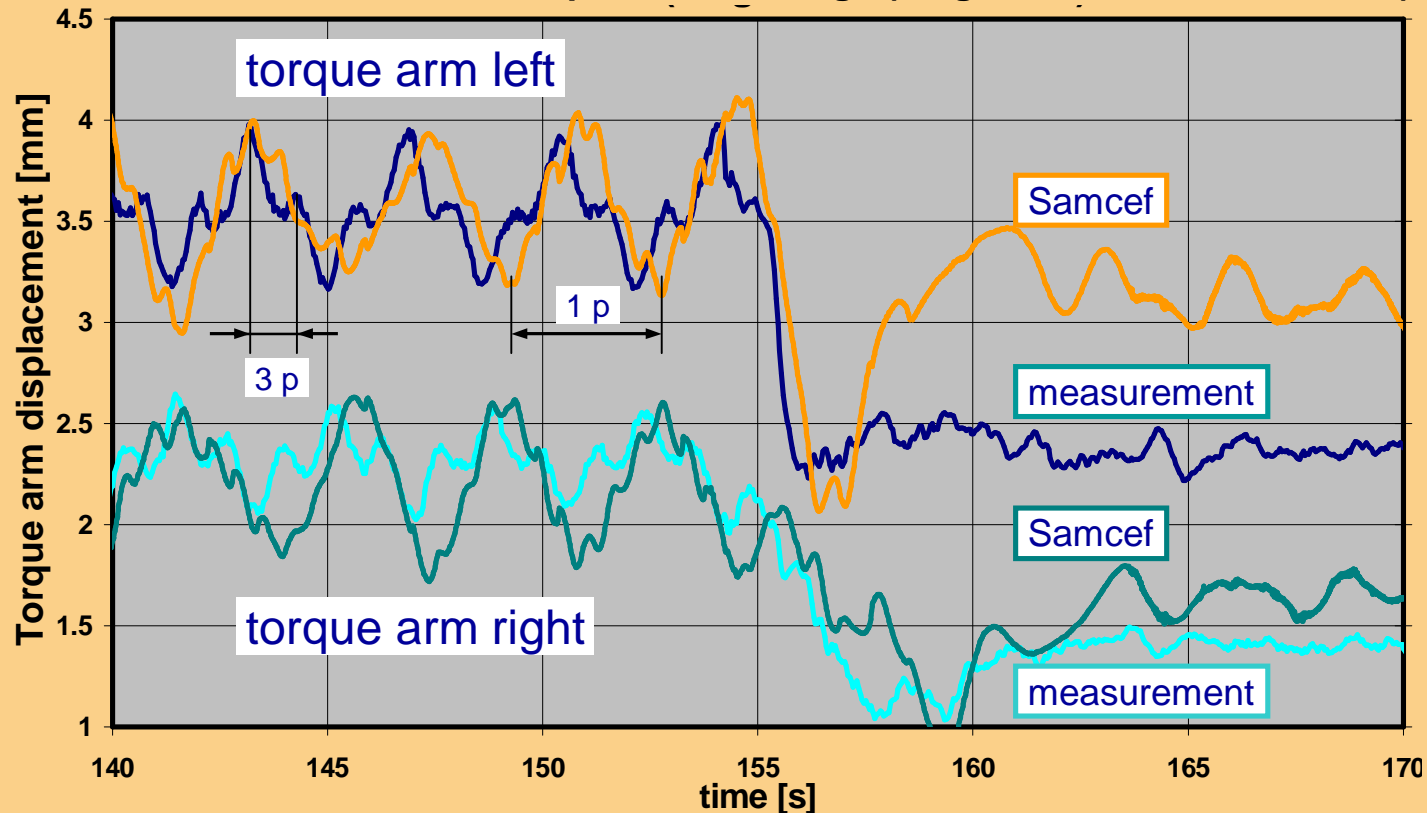

Main shaft & planet carrier coupling misalignment:  $\Rightarrow P_{\text{rotor}}$

Pitch error and misalignment produces torque arm displacement of frequency  $P_{\text{rotor}}$



SIXTH FRAMEWORK PROGRAMME

EWE C 2008 Session BW2 "UpWind" – Transmission & Conversion



# Gearbox rear – orbital movement

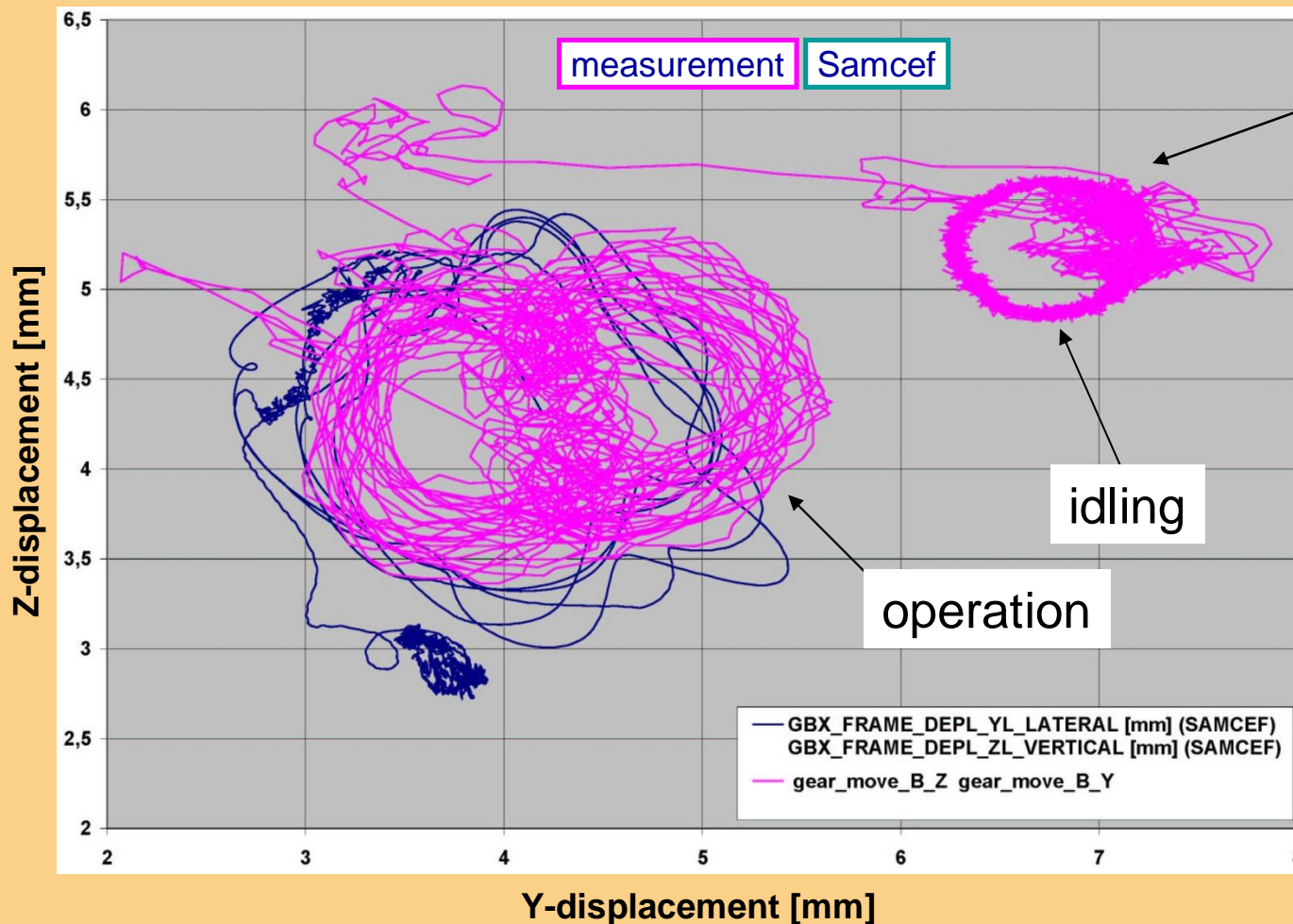

$\Delta t = 2.8 \text{ min}$   
1 rotor rotation  
(idling)

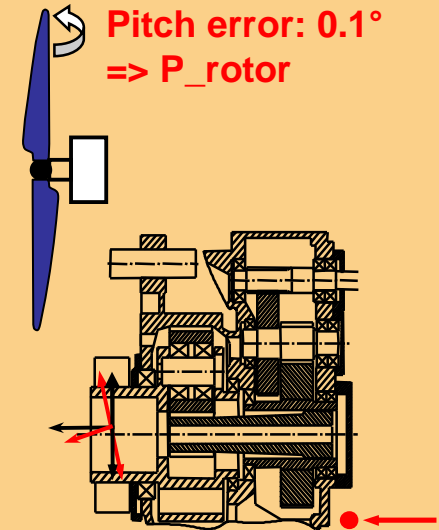

Pitch error:  $0.1^\circ$   
 $\Rightarrow P_{\text{rotor}}$

Main shaft & planet  
carrier coupling  
misalignment:  
 $\Rightarrow P_{\text{rotor}}$

Pitch error and misalignment of main shaft produces gearbox displacement of frequency  $P_{\text{rotor}}$



SIXTH FRAMEWORK PROGRAMME

EWEK 2008 Session BW2 "UpWind" – Transmission & Conversion



# Generators

- **Aalborg University:**

Comparison of different generator configurations

- **Delft University of Technology:**

Electromagnetic optimization of direct-drive generators

- **University of Edinburgh:**

Optimization of the mechanical structure of direct-drive generators

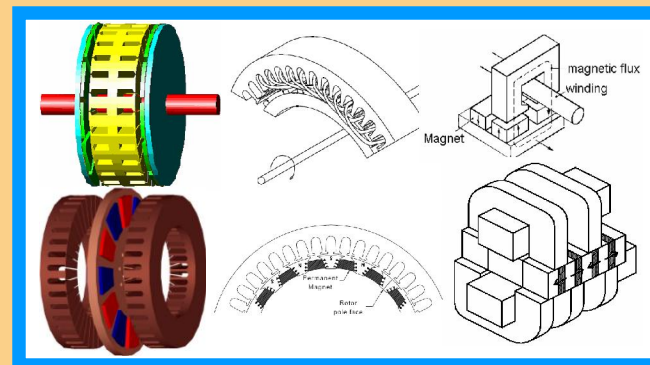
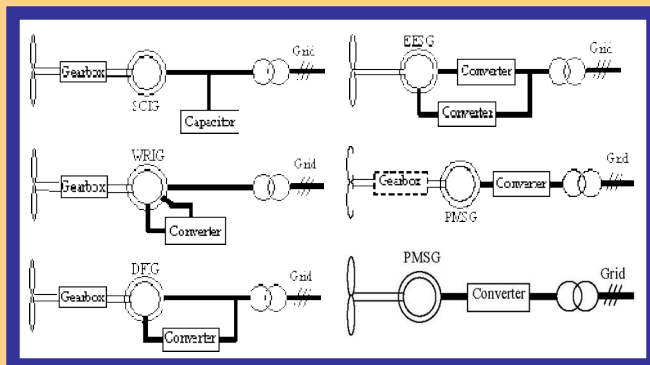
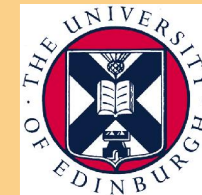

SIXTH FRAMEWORK PROGRAMME

EWEC 2008 Session BW2 "UpWind" – Transmission & Conversion



# Comparison of generator configurations

- ✧ Overview of various wind generator systems
  - Technical features, market situations
- ✧ Design models for evaluation of different WTG systems:
  - Drive trains (AEP, gearbox cost, weight, losses)
  - Induction generators and synchronous generators
  - Power electronic converter
- ✧ Comparison for the minimum generator system cost
  - Generator system cost includes:
    - active material
    - structural
    - gearbox (if present),
    - power electronic converter
    - other electrical subsystem (transformer, cable, switchgear)

# System cost / AEP per cost

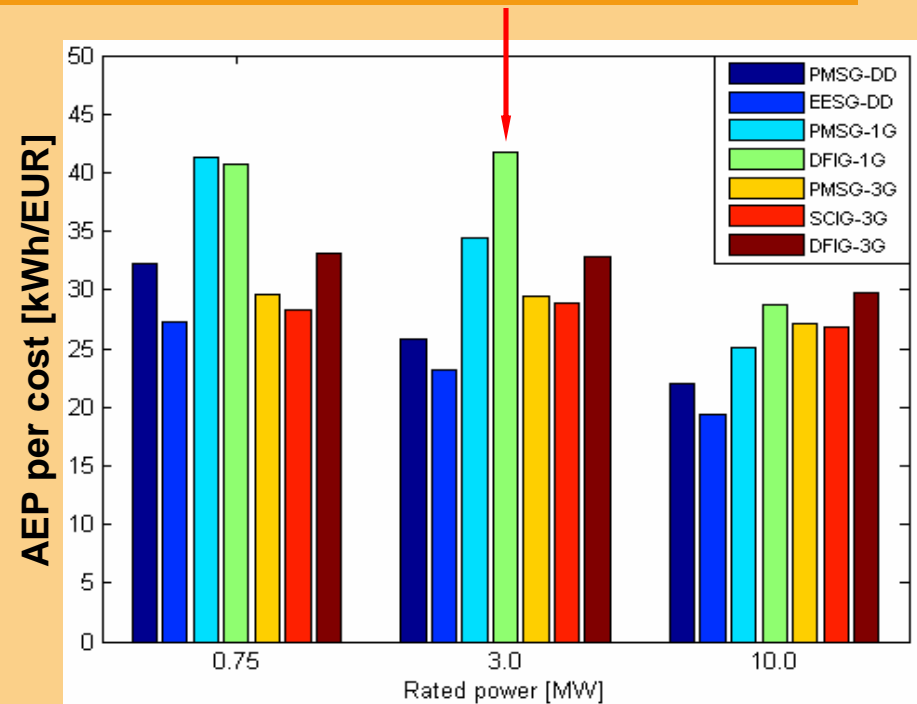
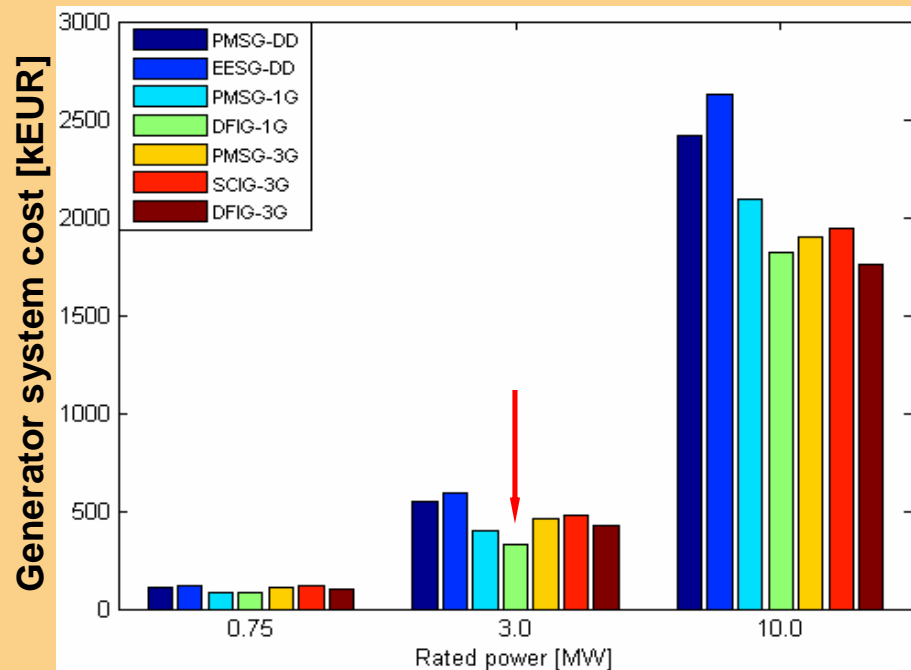

- *PMSG\_DD* PM synchronous
- *EESG\_DD* Wound rotor synchronous
- *PMSG\_1G* PM synchronous single gear stage
- *DFIG\_1G* Wound rotor induction single gear stage
- *PMSG\_3G* PM synchronous three gear stages
- *DFIG\_3G* Wound rotor induction three gear stages
- *SCIG\_3G* Squirrel cage induction three gear stages

# Selection of generator type

✧ For active mass reduction:

*Concept with short flux path required*

Radial Flux & Axial Flux  
PM machine: limited

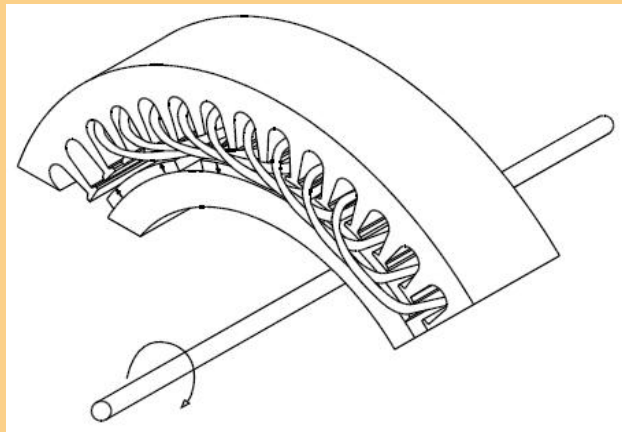

Transversal Flux  
PM machine: potential

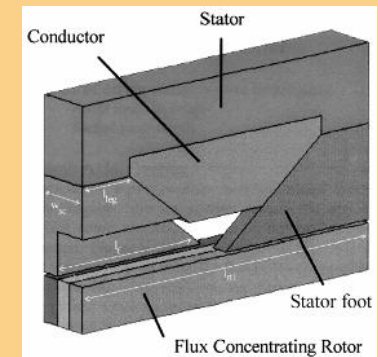
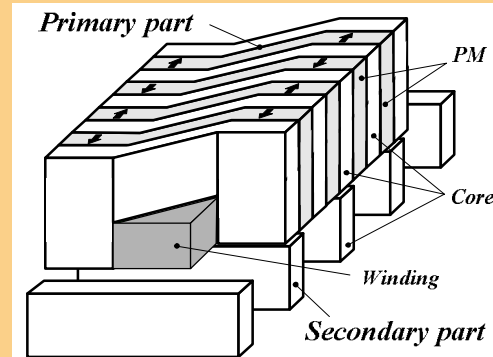

plural module  
concept

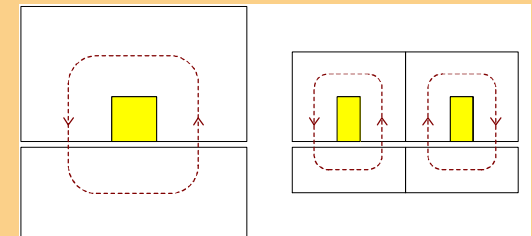

Analytical design procedure developed to assess TFPM machine.

# Rough design of 10 & 20 MW direct-drive RFPM generators

Power (Speed)	10 MW (10 rpm)	20 MW (7 rpm)
I/D	0.3 (2.4/7.96)	0.4 (4.1/10.3)
Mass [T]	77.3	174.8
Iron	57.4	127.1
Copper	12.7	27.1
PM	7.2	20.6
Loss [kW]	655	1306
Iron	54.4	109.4
Copper	300.7	596.9
Converter	300	600

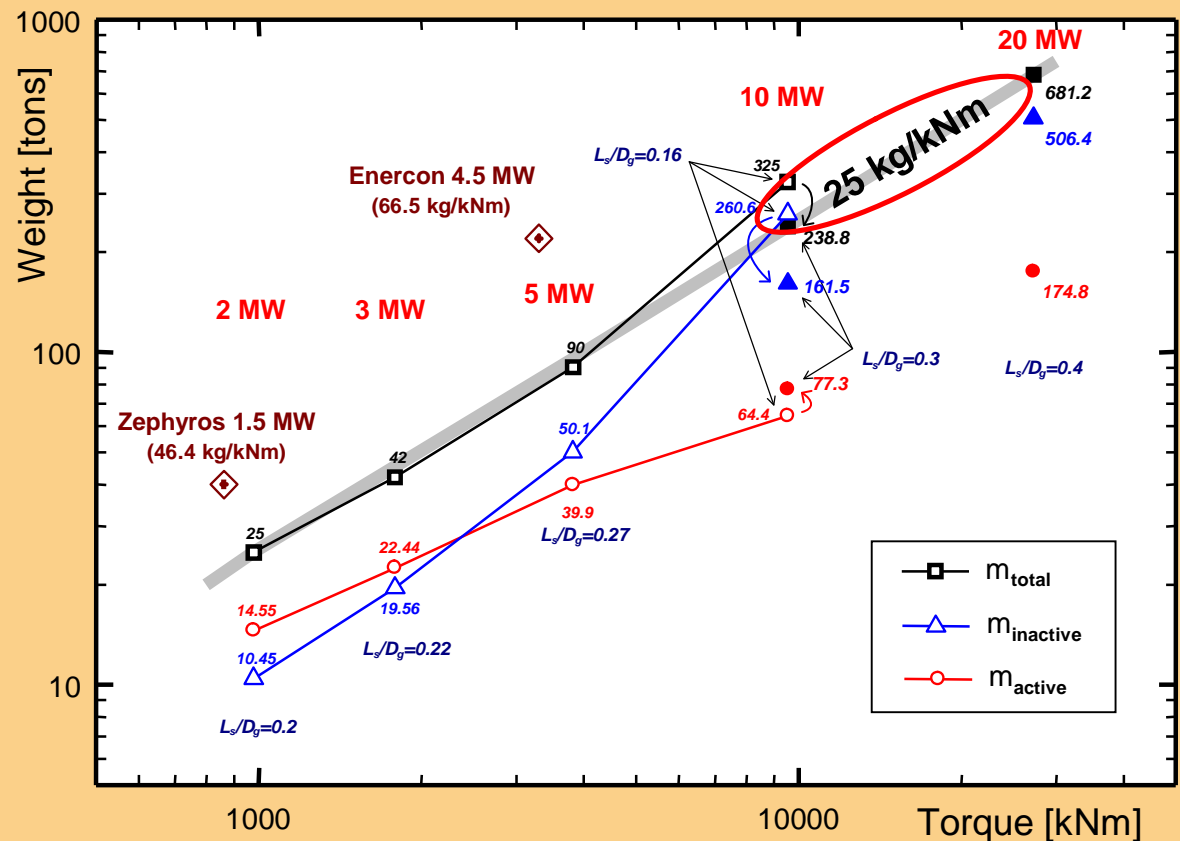

Note: 2, 3, 5 MW : McDonald et al (ICEM2006)

# Optimization of the mechanical structure of direct-drive generators

- ✧ The concept of ‘structural’ mass
  - Material required to maintain airgap, many forces at work
- ✧ The formulation of design tools to estimate the structural material
  - electromagnetically active and structural material must be simultaneously optimized
- ✧ The search for optimal shapes for these generators
  - shape optimization to find the ‘best’ mechanical structures

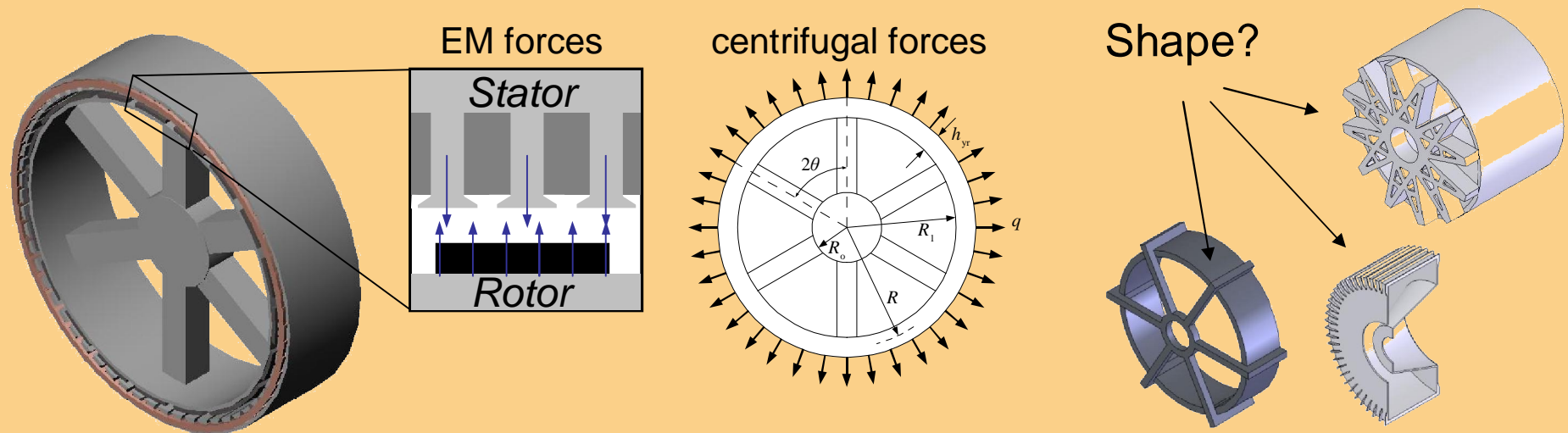

# Power Electronics - Converters

- ✦ **ISET:**  
Neutral point clamped converter
- ✦ **ROBOTIKER:**  
Matrix converters
- ✦ **GE Global Research:**  
Interleaved converter

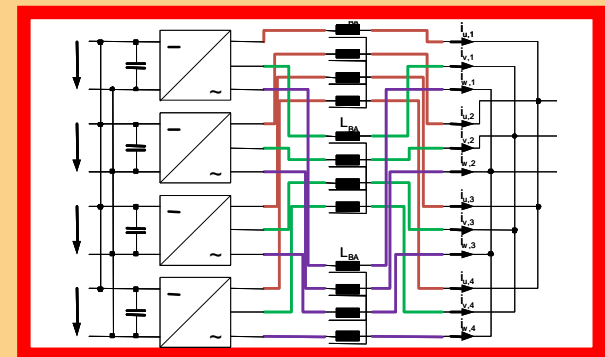
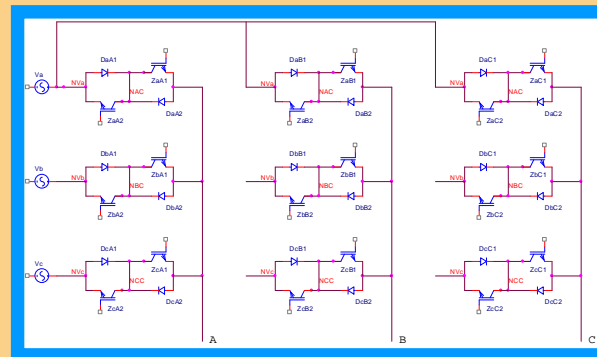
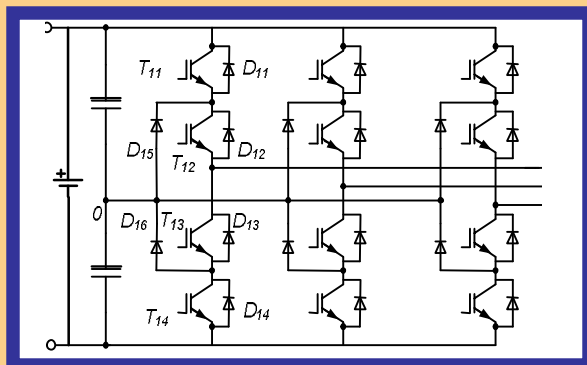

SIXTH FRAMEWORK PROGRAMME

EWEC 2008 Session BW2 "UpWind" – Transmission & Conversion



# Neutral point clamped converter (NPC)

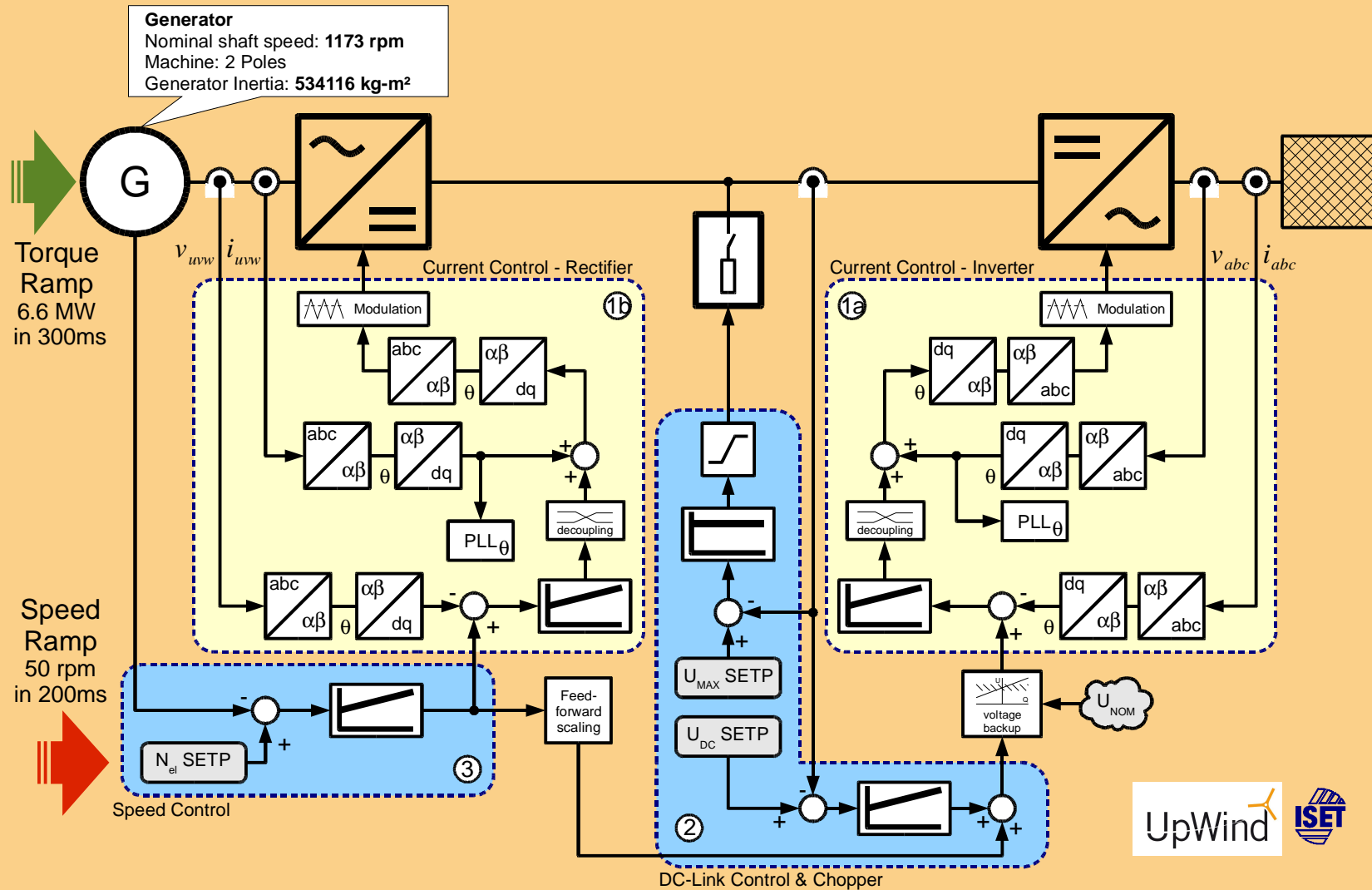

# Neutral point clamped converter (NPC)

- ✧ Control strategy for NPC converter developed
- ✧ Worst case operating conditions were considered
  - Sudden change in input power
  - Sudden change in the shaft speed setpoint
- ✧ Forwarding information about scheduled turbine power production may have positive impact on performance
  
- ✧ NPC has little or no redundancy in power electronic devices
- ✧ Good robustness against symmetrical and unsymmetrical grid faults to ground
- ✧ For prevention of isolation failures to ground a isolation transformer is required



# Matrix converter

- ✦ An “all silicon” AC/AC converter formed by  $n \times m$  bidirectional switches, without significant reactive elements.
- ✦ Promising technology that may contribute to the development of multi-megawatt wind turbines. Further research is needed:
  - Technological barrier: absence of tailor made bidirectional switches → cooperation with semiconductor manufacturers
  - Poor ride through capability against grid disturbances
  - Experimental validation
  - Fault tolerant behaviour

Not a mature technology

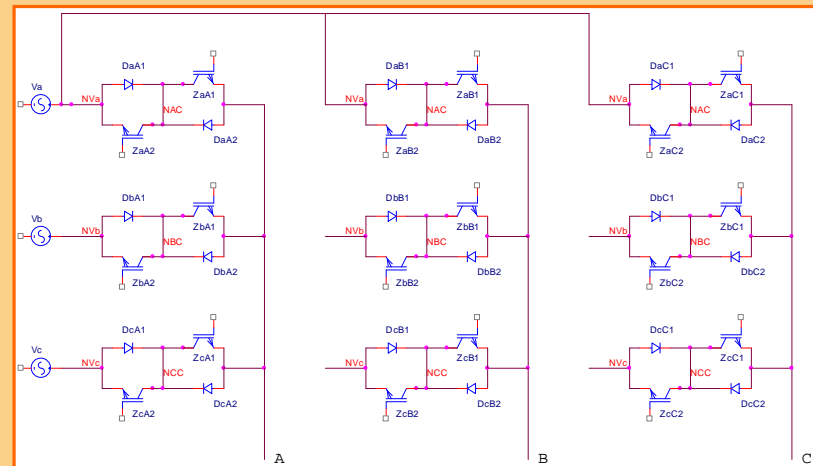



# Interleaved converter

## Conventional Design

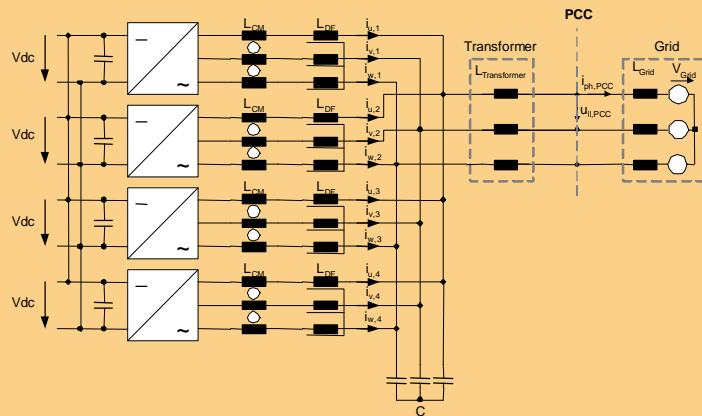

## New Design and Modulation Method

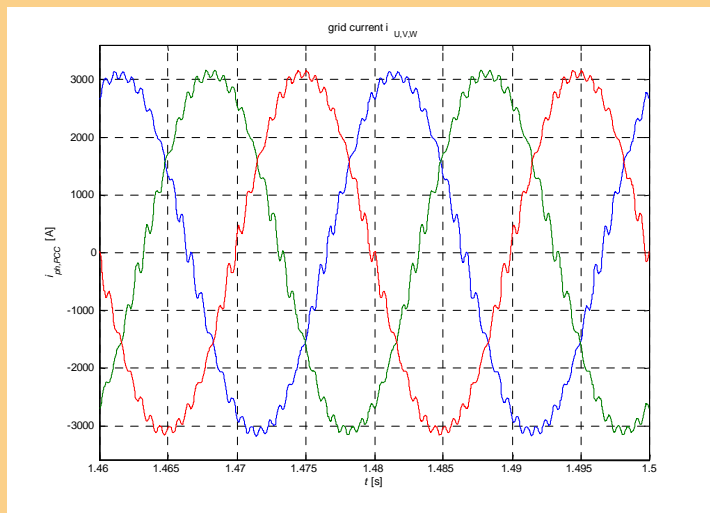
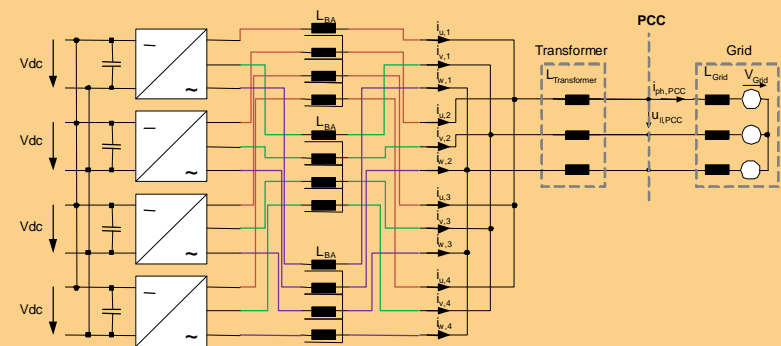

Phase currents at PCC

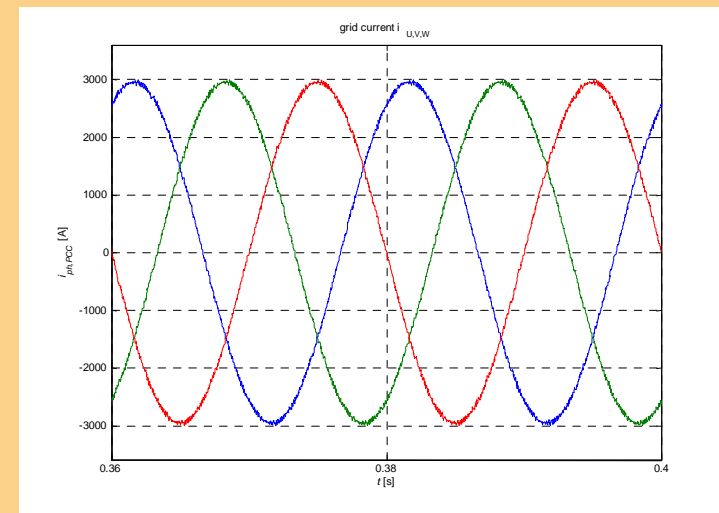

Phase currents at PCC



SIXTH FRAMEWORK PROGRAMME

EWEC 2008 Session BW2 "UpWind" – Transmission & Conversion





# Interleaved converter

- ✧ New modulation and control method for parallel connected inverters is proposed
- ✧ Modulation scheme uses a 5-level modulator and a cross current controller instead of 2-level modulation with phase shifted carriers
  - Better Voltage spectrum
  - No differential and no common mode choke required
- ✧ Disadvantage:
  - Large voltage differences between converters
  - Large cross currents
  - Compensation: a new balancing choke is required



# Conclusions

- ↘ Simulation tool for full flexible turbine simulation has been developed and compared against measurements
- ↘ First step of comparison is modeling the right effects / defects
- ↘ Simulation tool helps to quantify defects
  
- ↘ Generator topologies have been studied, compared and optimized in terms of electromagnetics and mechanics
- ↘ Models for multi-parameter optimization have been developed
  
- ↘ Power converter topologies have been compared and optimized
- ↘ No barriers for up-scaling in sight, no clear winning technology

